

# TRASERSCREEN DB-80

vibrating screener

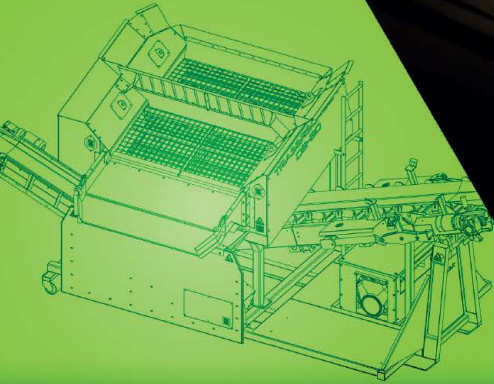
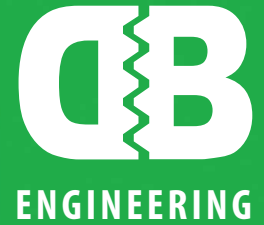

**Powerful** semi-mobile  
**vibrating screener**

AG für Baumaschinen Schmerikon

[www.agfs.ch](http://www.agfs.ch)  
[info@agfs.ch](mailto:info@agfs.ch)  
055 286 12 86





**Foldable conveyor in working position**



**Foldable conveyor in transport position**

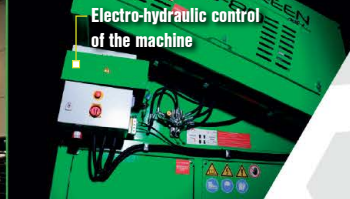

**Electro-hydraulic control of the machine**

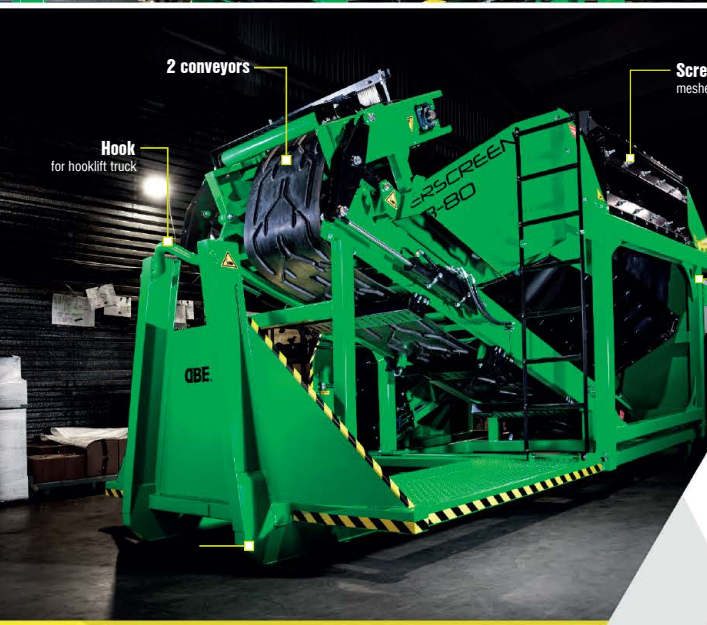

**2 conveyors**

**Hook for hooklift truck**

**Screen box**  
meshes made of high-quality spring steel

**Frame**  
high-strength steel construction ensures maximum stability

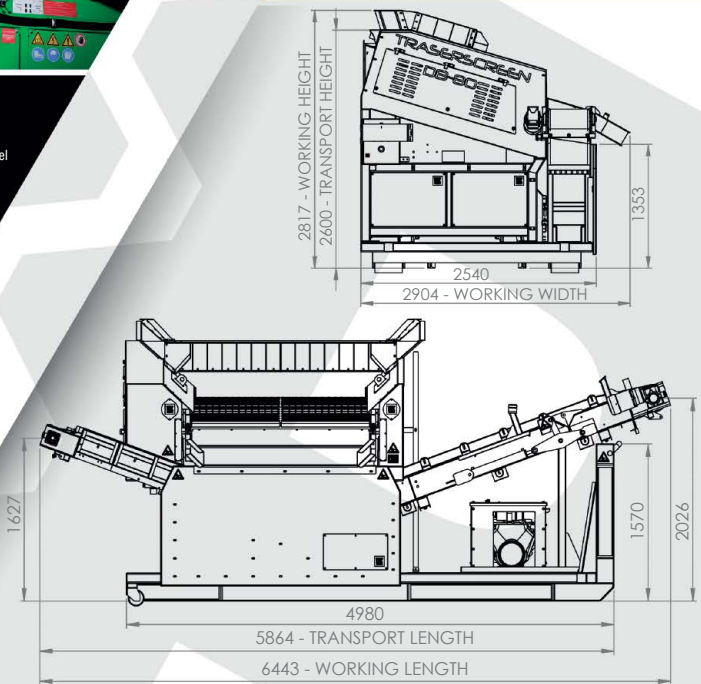

### Screening

- » Width x length: 1830 x 1850mm
- » Screening area: 3,39m<sup>2</sup>
- » Number of decks: 2
- » Number of fractions: 3
- » Number of meshes: 4 (910 x 1865mm)
- » Hopper width: 2386mm
- » Offtake width:

### Optional upgrades

- » Minimum requirement for the generator (22kVA)
- » Box for the generator
- » Hopper extension
- » Chute extension
- » Rear cover for screenbox
- » Feeder plate with stop rubber
- » Removable hook / non standard height of the hook

### Power

- » Screener: electric-hydraulic aggregate 5,5kW
- » Conveyor 1: 2,2kW
- » Conveyor 2: 2,2kW

### Weight

» 4800kg

### Transport method

- » Trailer
- » Hook lift truck

### Screening

» 37 - 150 t/h

\*Manual, keys and tachometer are included with the screener

