

# TRASERSCREEN DB-40XL

vibrating screener

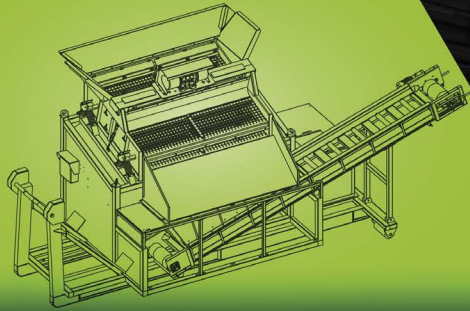

ENGINEERING



**Powerful semi-mobile  
vibrating screener**

AG für **B**aummaschinen Schmerikon

[www.agfbs.ch](http://www.agfbs.ch)  
[info@agfbs.ch](mailto:info@agfbs.ch)  
055 286 12 86





**quick change of meshes**  
of sizes from 0.2mm to 120mm

**powerful conveyor**  
gear motor

**Screen box on 8 steel springs**



**Conveyor**  
Built-in conveyor for mid-size fraction

**Screen box**  
meshes made of high-quality spring steel

**Mobility**  
4 lifting points at an ideal angle

**Mobility**  
Screener is on a skid frame for easier transportation on a hooklift truck

**Frame**  
high-strength steel construction ensures maximum stability

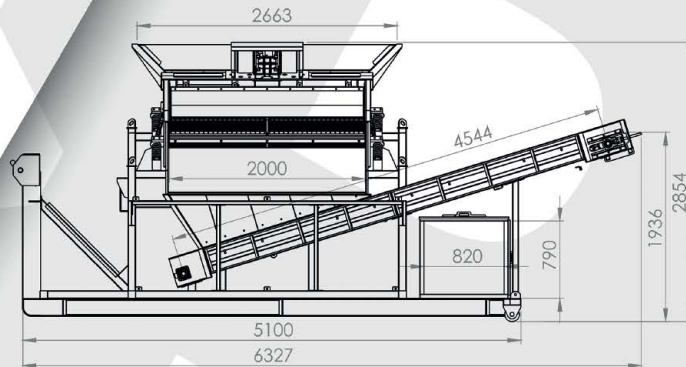
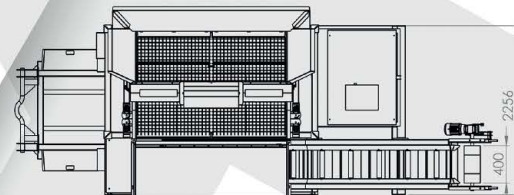

### Screening

- » Width x length: 2000 x 1460mm
- » Screening area: 2,92m<sup>2</sup>
- » Number of decks: 2
- » Number of fractions: 3
- » Number of meshes: 4 (995 x 1475mm)
- » Hopper width: 2663mm
- » Offtake width: 2690mm

### Optional upgrades

- » Minimum requirement for the generator (9kVA)
- » Hopper extension
- » Box for the generator

### Power

- » 1,5kW screener
- » 1,5kW conveyor

### Weight

- » 2800kg

### Transport method

- » Trailer
- » Hook-lift truck

### Screening

- » 15 60 t/h