

TRASERSCREEN DB-40SCT

Vibrating screener

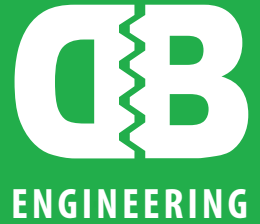

**Powerful mobile
vibrating screener**



AG für **B**aummaschinen Scherikon

www.agfbs.ch
info@agfbs.ch
055 286 12 86





Wheel cover plate

Powerful petrol generator

Fine fraction conveyor



Screen box
meshes made of high-quality spring steel

Mobility
4 lifting points

Frame
high-strength steel construction ensures maximum stability

Conveyor
for fine fraction

Stability
4 stabilizing legs of the trailer

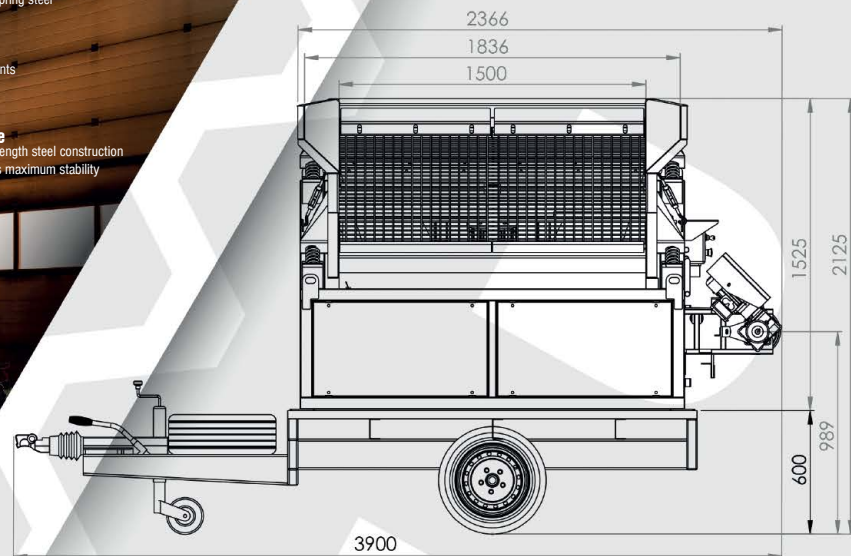

Screening

- » Width x length: 1500 x 1450mm
- » Screening area: 2,18m²
- » Number of decks: 1
- » Number of fractions: 2
- » Number of meshes: 2 (745 x 1465mm)
- » Hopper width: 1836mm

Optional upgrades

- » Lifting chains
- » Minimum requirement for the generator (7 kVA)

Power

- » Screener: 0.55kW
- » Conveyor: 0.75kW

Weight

- » 1300kg

Transport method

- » Trailer
- » Trailer category O2

Screening

- » 15 - 38t/h

*Possibility of delivery with petrol generator.

