

TRASERSCREEN DB-40LS

vibrating screener

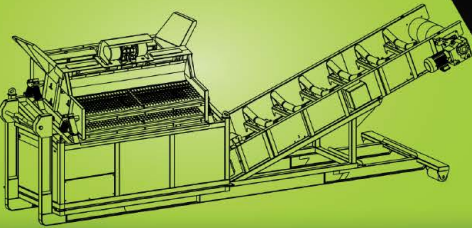

ENGINEERING



**Powerful semi-mobile
vibrating screener**



AG für Baumaschinen Scherikon

www.agfbs.ch
info@agfbs.ch
055 286 12 86



quick change of meshes
of sizes from 0,2mm to 120mm



powerful conveyor gear motor

Screen box on 8 steel springs

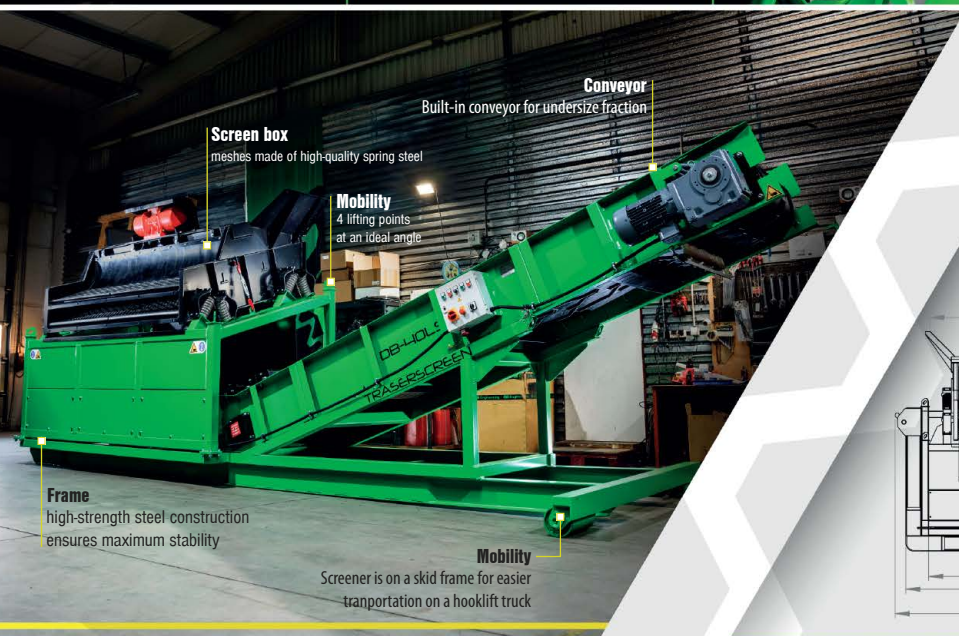

Screen box

meshes made of high-quality spring steel

Mobility

4 lifting points
at an ideal angle

Conveyor
Built-in conveyor for undersize fraction

Frame
high-strength steel construction
ensures maximum stability

Mobility

Screener is on a skid frame for easier
transportation on a hooklift truck

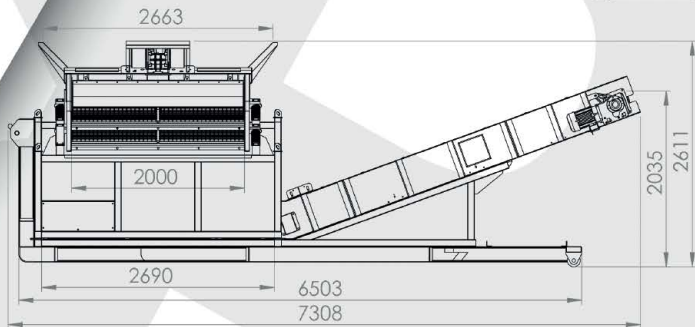
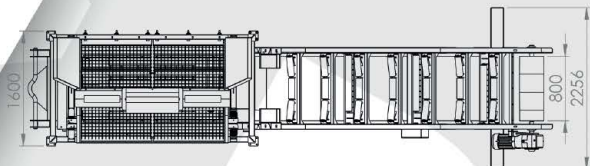

Screening

- » Width x length: 2000 x 1460mm
- » Screening area: 2,92m²
- » Number of decks: 2
- » Number of fractions: 2
- » Number of meshes: 4 (995 x 1475mm)
- » Hopper width: 2663mm
- » Offtake width:

Optional upgrades

- » Minimum requirement for the generator (13.5 kVA)
- » Hopper extension

Power

- » 1,5kW screener
- » 4kW conveyor

Weight

» 3200kg

Transport method

- » Trailer
- » Hook lift truck

Screening

» 15 - 60 t/h

