

# TRASERSCREEN DB-40L/C

Vibrating screener

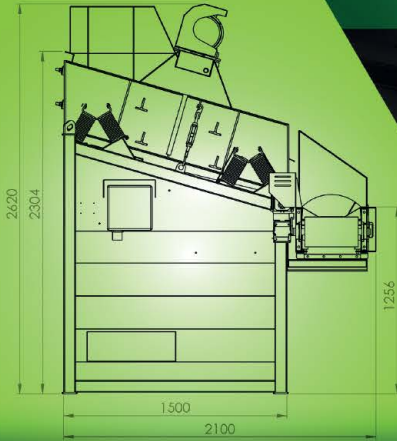

**Powerful semi-mobile  
vibrating screener**

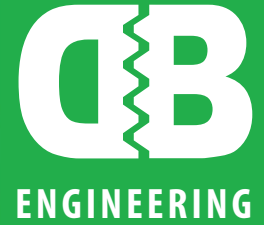

AG für Baumaschinen Scherikon

[www.agfs.ch](http://www.agfs.ch)  
[info@agfs.ch](mailto:info@agfs.ch)  
055 286 12 86



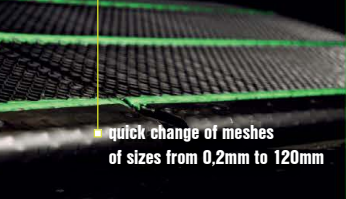

**quick change of meshes**  
of sizes from 0,2mm to 120mm



**Mobility**  
the transport consoles are included



**Screen box**  
on 8 steel springs

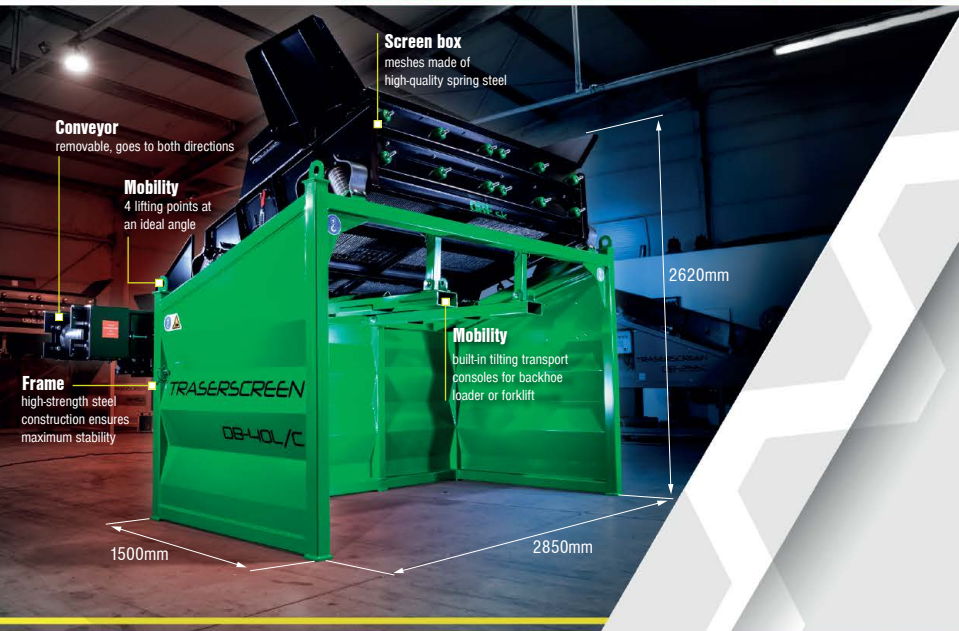

**Conveyor**  
removable, goes to both directions

**Mobility**  
4 lifting points at  
an ideal angle

**Screen box**  
meshes made of  
high-quality spring steel

2620mm

**Mobility**  
built-in tilting transport  
consoles for backhoe  
loader or forklift

**Frame**  
high-strength steel  
construction ensures  
maximum stability

1500mm

2850mm

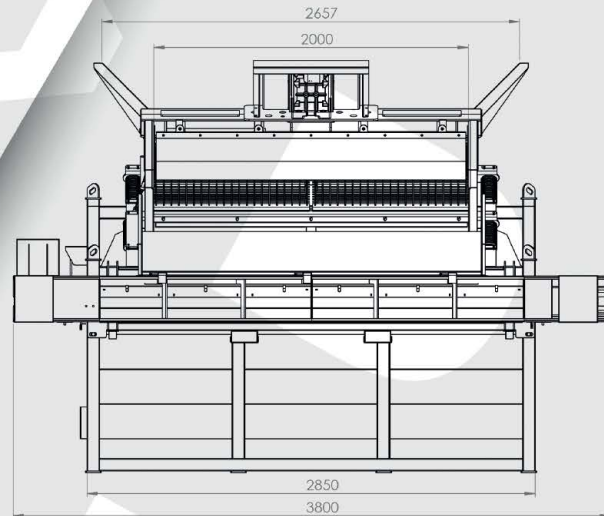

### Screening

- » Width x length: 2000 x 1460mm
- » Screening area: 2,92m<sup>2</sup>
- » Number of decks: 2
- » Number of fractions: 3
- » Number of meshes: 4 (995 x 1475mm)
- » Hopper width: 2657mm
- » Offtake width: 2690mm



### Optional upgrades

- » Lifting chains
- » Minimum requirement for the generator (7 kVA)
- » Hopper extension

### Power

- » 1,5kW - screener
- » 1,5kW - conveyor



### Weight

- » 1900kg



### Transport method

- » Trailer



### Screening

- » 15 ~ 60 t/h