

# TRASERSCREEN DB-25S

Vibrating screener

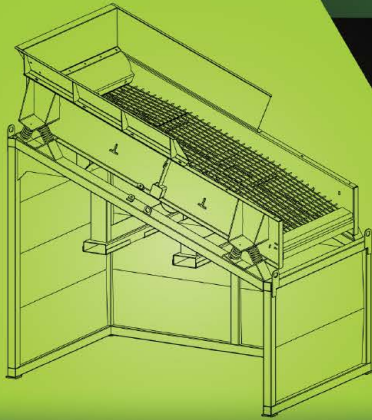

ENGINEERING



**Powerful  
vibrating screener**



AG für **B**aummaschinen Schmerikon

[www.agfbs.ch](http://www.agfbs.ch)  
[info@agfbs.ch](mailto:info@agfbs.ch)  
055 286 12 86





Quick change of meshes of sizes from 0.2mm to 120mm



Mobility the transport consoles are included

Transport pallet supplied with the screener



Screen box on 8 steel springs



**Mobility**  
4 lifting points at an ideal angle

**Screen box**  
meshes made of high-quality spring steel

**Frame**  
high-strength steel construction ensures maximum stability

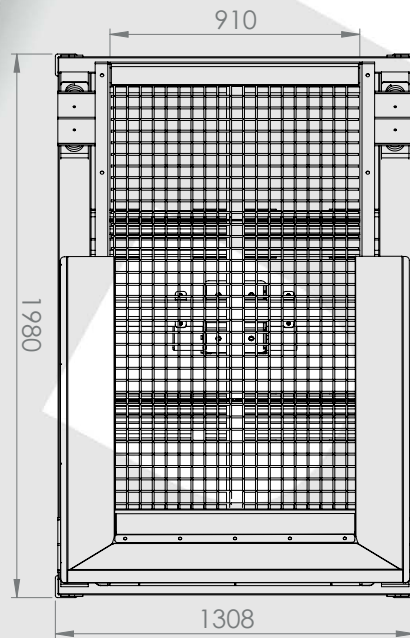

### Screening

- » Width x length: 910 x 1850mm
- » Screening area: 1,68m<sup>2</sup>
- » Number of decks: 1
- » Number of fractions: 2
- » Number of meshes: 1 (900 x 1865mm)
- » Hopper width: 1220mm
- » Offtake width: 1840mm

### Optional upgrades

- » Hopper extension is included
- » Transport pallet is included
- » Minimum requirement for the generator (5,5 kVA)
- » Lifting chains
- » Chute extension

**Power**  
» 0,55kW

**Weight**  
» 500kg

**Transport method**  
» Trailer

**Screening**  
» 7 - 25 t/h