

TRASERSCREEN DB-25SC

Vibrating screener

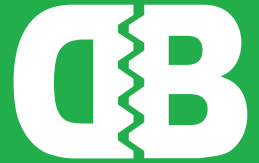

ENGINEERING

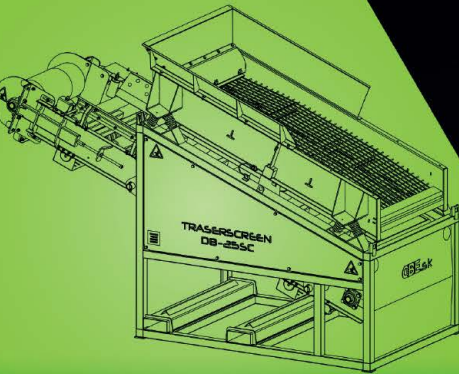

Powerful vibrating screener



AG für Baumaschinen Schmerikon

www.agfs.ch
info@agfs.ch
055 286 12 86



- quick change of meshes
- sizes from 0.2mm to 120mm

Mobility

The transport pallet supplied with the screener

Screen box on 8 steel springs

Conveyor

conveyor for undersize fraction

Mobility

4 lifting points at an ideal angle

Screen box

meshes made of high-quality spring steel

Frame

high-strength steel construction ensures maximum stability

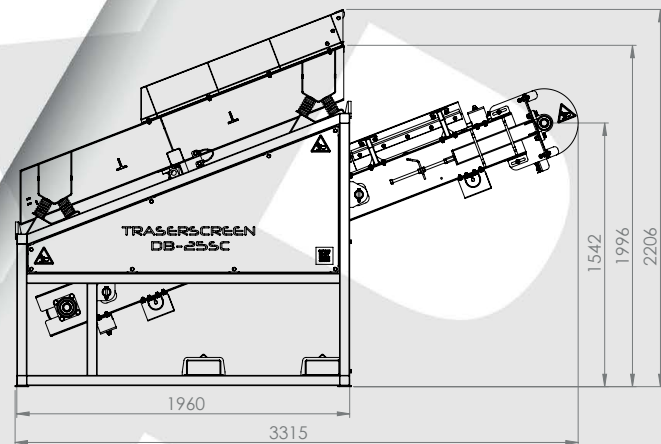

2206mm

910mm

1960mm

1960

3315

1542

1996

2206

Screening

- » Width x length: 910 x 1850mm
- » Screening area: 1,68m²
- » Number of decks: 1
- » Number of fractions: 2
- » Number of meshes: 1 (900 x 1865mm)
- » Hopper width: 1220mm

Optional upgrades

- » Hopper extension is included
- » Transport pallet is included
- » Minimum requirement for the generator (7 kVA)
- » Lifting chains
- » Chute extension
- » Extended side skirt plates on the conveyor

Power

- » 0,55kW screener
- » 2,2kW conveyor

Weight

- » 1100kg

Transport method

- » Trailer

Screening

- » 7 ~ 25 t/h