

TRASERSCREEN DB-100TC

vibrating screener

DB
ENGINEERING

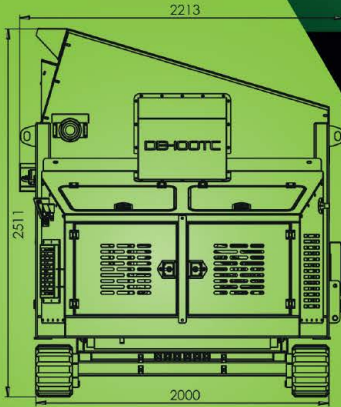

Powerful mobile
vibrating screener
tracked screener



www.agfs.ch
info@agfs.ch
055 286 12 86





Conveyor belt width 1200mm



Hydraulic orbital motor



Remote control



Light signalling
for greater security

Mobility
4 lifting points at an ideal angle

Screen box
Meshes made of high-quality spring steel

Conveyor
for a fine fraction

Drive unit

Mobility
Tracked undercarriage
Protective cover
foldable tracked undercarriage cover

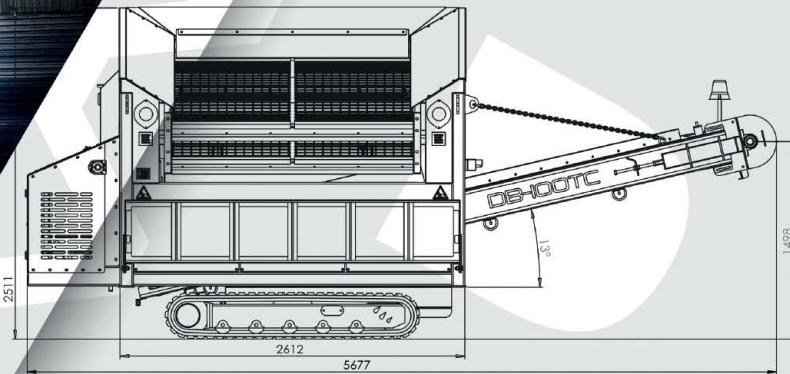

Screening

- » Width x length: 1830 x 1850mm
- » Screening area: 3,39m²
- » Number of decks: 2
- » Number of fractions: 2
- » Number of meshes: 4 (910 x 1865mm)
- » Hopper width: 257mm
- » Offtake width:



Power

- » Kubota diesel engine 18,5kW



Weight

- » 4400kg



Transport method

- » Trailer



Screening

- » 37 - 150 t/h

*Manual, keys, tachometer and remote control are included with the screener.

