

TRASERSCREEN DB-100T

vibrating screener

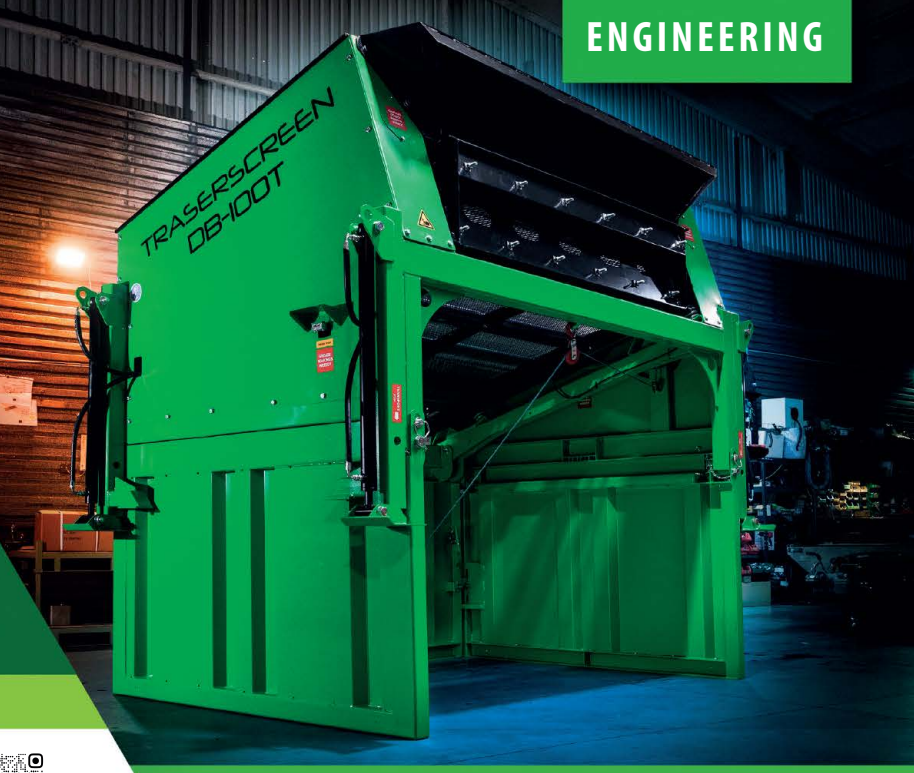

ENGINEERING



Powerful mobile
vibrating screener

AG für Baumaschinen Schermerikon

www.agfs.ch
info@agfs.ch
055 286 12 86





Kubota diesel engine 7kW

Hydraulic leg

Electric reel



Mobility
4 lifting points at an ideal angle

Screen box
Meshes made of high-quality spring steel

Frame
High-strength steel construction ensures maximum stability

Motor unit

Slided out hydraulic leg

2926mm

2220mm

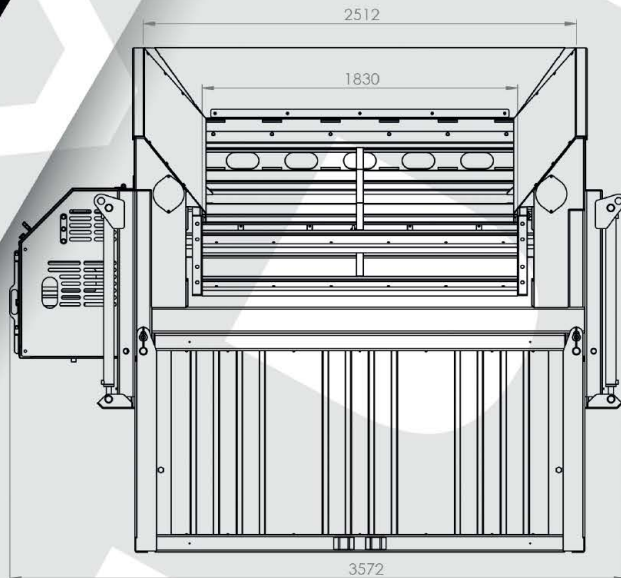

Screening

- » Width x length: 1830 x 1850mm
- » Screening area: 3,39m²
- » Number of decks: 2
- » Number of fractions: 2
- » Number of meshes: 4 (910 x 1865mm)
- » Hopper width: 2500mm
- » Offtake width: 2400mm

Optional upgrades

- » 3 fractions chute
- » Road safety kit

Power

- » Kubota diesel engine 7kW

Weight

- » 2200kg conveyor
- » 500kg trailer

Transport method

- » Trailer category O2

Screening

- » 37 - 150 t/h