

TRASERSCREEN DB100S

Vibrating screener

DB
ENGINEERING

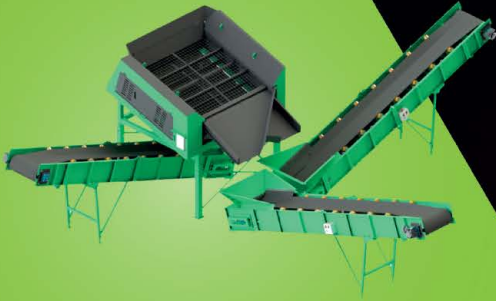

**Powerful
vibrating screener**



AG für **B**aummaschinen Schmerikon

www.agfbs.ch
info@agfbs.ch
055 286 12 86



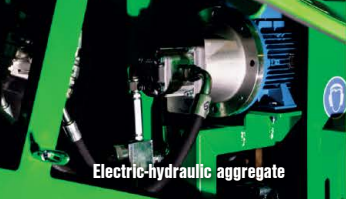

Electric-hydraulic aggregate



Lifting points



2072mm

2746mm

Screen box

Meshes made of high-quality spring steel

Frame

High-strength steel construction ensures maximum stability

Transport

Transport pallet is included with the screener

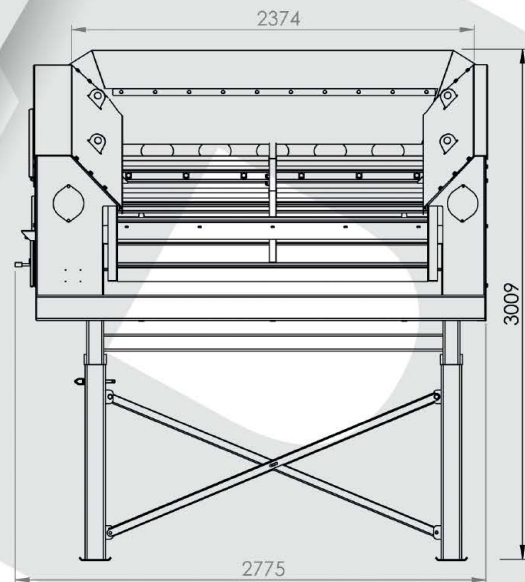

Screening

- » Width x length: 1830 x 1850mm
- » Screening area: 3,39m²
- » Number of decks: 2
- » Number of fractions: 2
- » Number of meshes: 4 (910 x 1865mm)
- » Hopper width: 2374mm

Optional upgrades

- » Hopper extension
- » Feeder plate with stop rubber
- » Minimum requirement for generator (22kVA with 3xPC105 or 13,5kVA when on its own)

Power

- » Electric-hydraulic aggregate 5,5kW

Weight

- » 2200kg

Transport method

- » Trailer

Screening

- » 37 - 150 t/h

*3 fractions chute and a rubber curtain are included with the screener. Transport pallet is included with the screener.

